

Certified by
 Lab Test Certification
 Meets: ANSI Z21.97-2014
 CSA 2.41-2014
 CSA C22.2 No. 3-M1998 (R2014)

⚠ WARNING ⚠

Improper installation, adjustment, alteration, service or maintenance can cause injury or property damage. Read the installation, operating and maintenance instructions thoroughly before installing or servicing this equipment.

⚠ WARNING ⚠

Do not store or use gasoline or other flammable vapors and liquids in vicinity of this or any other appliance.

An LP-cylinder not connected for use shall not be stored in the vicinity of this or any other appliance.

⚠ WARNING ⚠

**FOR OUTDOOR
 USE ONLY**

⚠ DANGER



CARBON MONOXIDE HAZARD

This appliance can produce carbon monoxide which has no odor.

Using it in an enclosed space can kill you.

Never use this appliance in an enclosed space such as a camper, tent car or home.

⚠ WARNING ⚠

For Use with NATURAL or LP GAS Only
NO SOLID FUELS TO BE USED WITH THIS SYSTEM

⚠ DANGER ⚠

If you smell gas:

1. Shut off gas to the appliance.
2. Extinguish any open flame.
3. If odor continues, keep away from appliance and immediately call your gas supplier or fire department.

Installation must conform with local codes or, in the absence of local codes, with the *National Fuel Gas Code, ANSI Z223.1 / NFPA 54, or International Fuel Gas Code.*

The appliance, when installed, must be electrically grounded in accordance with local codes or, in the absence of local codes, with the *National Electric Code, ANSI/NFPA 70*, if applicable.

INSTALLER: Leave this manual with the appliance.
CONSUMER: Retain this manual for future reference.

⚠ AVERTISSEMENT ⚠

Une installation, un ajustement, une modification, une réparation ou un entretien inapproprié peuvent être la cause de blessures ou de dommages. Veuillez lire attentivement les instructions d'installation, d'utilisation et d'entretien avant d'installer ou de réparer ce matériel.

⚠ AVERTISSEMENT ⚠

Ne pas entreposer ni utiliser de l'essence ni d'autres vapeurs ou liquides inflammables dans le voisinage de l'appareil, ni de tout autre appareil.

Une bouteille de propane qui n'est pas raccordée en vue de son utilisation, ne doit pas être entreposée dans le voisinage de cet appareil ou de tout autre appareil.

⚠ AVERTISSEMENT ⚠

Pour utilisation
à l'extérieur seulement.

⚠ DANGER



MONOXYDE DE CARBONE
Cet appareil peut produire du monoxyde de carbone, un gaz inodore.

L'utilisation de cet appareil dans des espaces clos peut entraîner la mort.

Ne jamais utiliser cet appareil dans un espace clos comme un véhicule de camping, une tente, une automobile ou une maison.

⚠ AVERTISSEMENT ⚠

Pour utilisation avec naturel ou propane ne gaz seulement
Aucun combustibles solides pour être utilisés avec ce système

⚠ DANGER ⚠

S'il y a une odeur de gaz:

1. Coupez l'admission de gaz de l'appareil.
2. Éteindre toute flamme nue.
3. Si l'odeur persiste, éloignez-vous de l'appareil et appelez immédiatement le fournisseur de gaz ou le service d'incendie.

⚠ AVERTISSEMENT ⚠

Ne pas utiliser cet appareil s'il a été plongé, même partiellement, dans l'eau. Appeler un technicien qualifié pour inspecter l'appareil et remplacer toute partie du système de commande et toute commande qui a été plongée dans l'eau.

Table of Contents

Gas and Electrical Requirements	Page 4
Clearance from Combustibles	Page 4
Parts List	Page 5
Overview of Completed Install	Page 6
Gas and Electrical Connections on Ignition Control Box	
Installation	Page 7
Initial Startup	Page 10
Gas Leak Test	
Ensure Proper Operation	Page 11
Operation	Page 12
Maintenance	Page 13
Replacement Parts	Page 14
Troubleshooting	Page 15

Gas Requirements

Fuel Type – Before making gas connections ensure appliance being installed is compatible with the available gas type. Check the label on the appliance to confirm appliance gas type requirement.

Gas Pressure – Proper input gas pressures are required for optimum appliance performance.

Gas Pressure Requirements

Pressure	Natural Gas	Propane
Minimum	3.5" W.C. / 1/8 psi	8.0" W.C. / 1/3 psi
Nominal	7.0" W.C. / 1/4 psi	11.0" W.C. / 1/3 psi
Maximum	14.0" W.C. / 1/2 psi	14.0" W.C. / 1/2 psi

Electrical Requirements

⚠ WARNING ⚠

The Commercial Grade All Weather Electronic Ignition System operates on 24 Volts AC power ONLY

DO NOT Attempt to Power using 110 Volts AC Power – Damage WILL RESULT

Acceptable Input Voltages to Supplied 24 Volt AC Transformer

110 / 210 / 220 / 240 Volt AC

(Supplied 24 Volt AC Transformer compatible with all voltages listed above)

(Read label on supplied transformer for proper connection information)

Recommended Wire Size

12 gauge wire for all installations

Clearance from Combustibles

⚠ WARNING – FIRE RISK ⚠

Provide Adequate Clearance from Combustibles as shown below

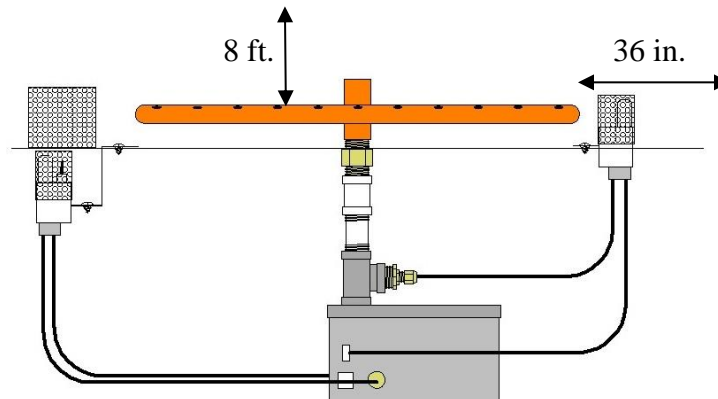

Parts List

Below is a picture of the parts to be used for the Installation of the Commercial Grade AWEIS – Recessed Pilot Burner Configuration

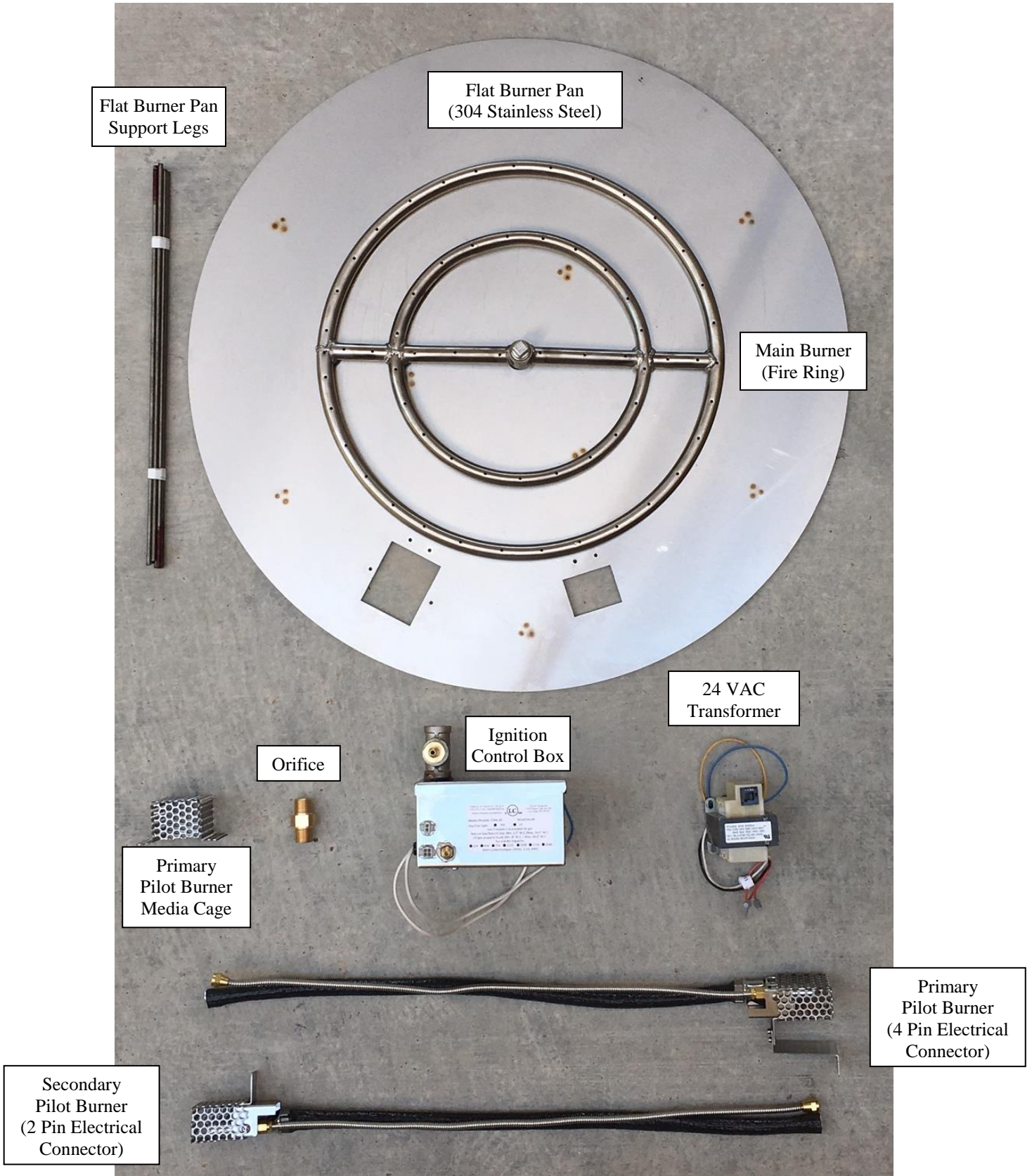

Illustration showing Overview of Completed Installation

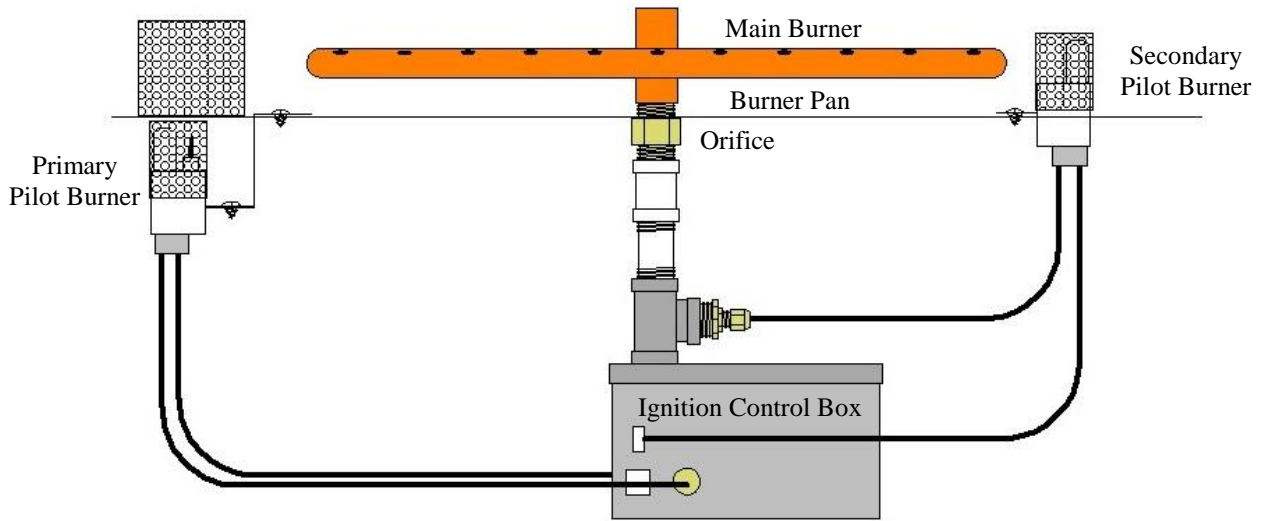
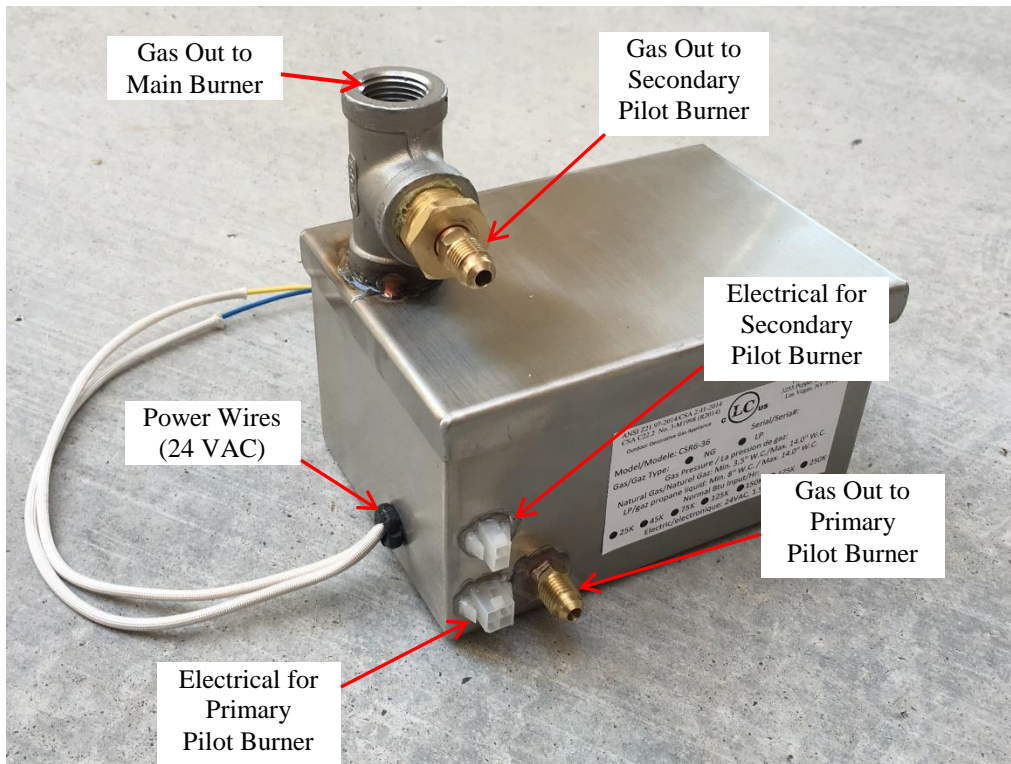

Illustration showing Gas and Electrical Connections on Ignition Control Box



Installation of Commercial Grade Ignition System – Recessed Pilot Burner Configuration

Note: Installation should be done by a qualified service technician that is locally licensed

Step 1: Gas & Electric Rough In

Recommended wire gauge: 12 gauge
Gas Pressure: 0.5 psi or less



Step 2: Apply pipe dope or teflon tape suitable for use with gas to gas riser. Thread the Ignition Control Box onto the Gas Line and tighten. Assemble Flat Burner Pan and support legs and install in bowl/firepit. In these instructions we will be assembling a free standing firepit in order to be able to show all installation steps clearly.

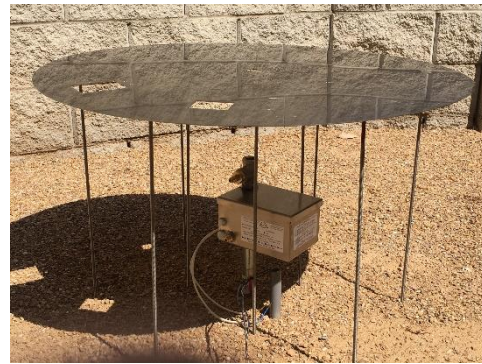

Step 3: Make the electrical connection between the Ignition Control Box Power Wires and the 12 gauge wire leading from the 24 Volt AC Transformer using the appropriate wire nuts. Recommend using Grease Filled Wire Nuts.



Step 4: Insert the Primary Pilot Burner gas and electrical connections through the larger opening in the Flat Burner Pan and connect to the Ignition Control Box to the appropriate connection points shown on page 6 of this manual.



Step 5: Secure the Primary Pilot Burner to the Flat Burner Pan as shown in the photo at right.



Step 6: Secure the Primary Pilot Burner Media Cage to the Flat Burner Pan as shown in the photo at right.



Step 7: Insert the Secondary Pilot Burner gas and electrical connections through the remaining opening in the Flat Burner Pan and connect to the Ignition Control Box to the appropriate connection points shown on page 6 of this manual.



Step 8: Secure the Secondary Pilot Burner to the Flat Burner Pan as shown in the photo at right.



Step 9: Measure the distance between the Flat Burner Pan and the outlet of the Ignition Control Box. Install a pipe nipple with coupling in the outlet of the Ignition Control Box.

Recommended minimum vertical clearance between the outlet and the burner pan is 3 inches.



Step 10: Install Brass Orifice in center hole of Flat Burner Pan into coupling described in Step 9 above.



Step 12: Install the Fire Ring as shown at right. Installation is complete



Initial Startup

(To be performed by Installer)

During the Initial Startup the goal is to check for gas leaks and ensure proper operation.

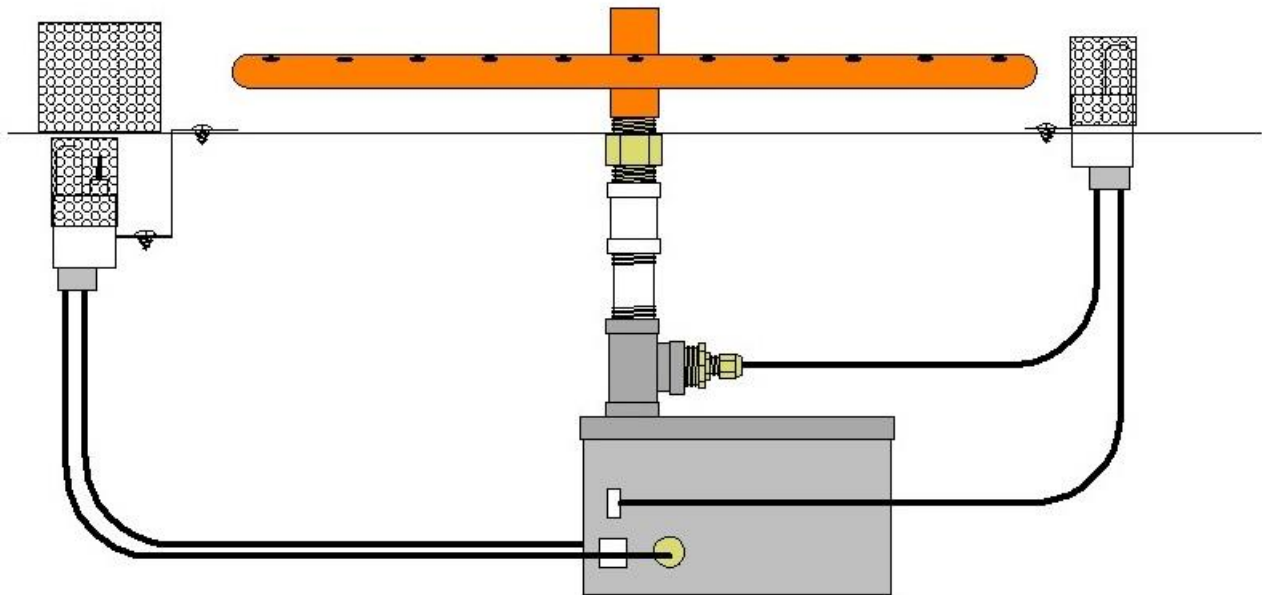

Gas Leak Test

1. Using either a soapy water solution in a spray bottle or gas “sniffer” instrument test the gas connections between the gas line and the inlet to the Ignition Control Box. Prior to start up this is the only part of the system that has gas in it.
2. Start the system by turning electrical power on and check for leaks on all other gas connections.
Note: This is the ONLY time you will be able to check for leaks on the Primary Pilot Burner startup. Once the Secondary Pilot Burner ignites, the gas will be turned off to the Primary Pilot Burner. For this reason you will want to first check for gas leaks from the Primary Pilot Burner.
3. If any leaks are detected be sure to snug up the connections and retest until there are no leaks.

Ensure Proper Operation

The following is a description of the Normal Sequence of Operation for the Commercial Grade AWEIS System:

Power – On

Immediately power is applied to the Hot Surface Igniter in the Primary Pilot Burner

4 seconds after Power is turned On:

- Primary Pilot Burner Gas Valve (located inside the Ignition Control Box) is opened, allowing gas to flow to the Primary Pilot Burner.



Assuming Ignition of the Primary Pilot Burner two things occur:

- Main Gas Valve is opened allowing gas to flow to Fire Ring and Secondary Pilot Burner
- Hot Surface Igniter is turned off



Assuming the flame from the Primary Pilot Burner ignites the gas flowing to the fire ring, the flame travels around the fire ring to the Secondary Pilot Burner and ignites the gas from it.

Within 5 seconds of the Secondary Pilot Burner igniting, the Primary Pilot Burner Gas Valve is turned off thereby stopping the flow of gas to the Primary Pilot Burner.



Power – Off

Fire feature turns off completely

During Initial Startup ensure the firepit operates as described above

Operation

▲ WARNING ▲

Do NOT use this appliance if any part has been under water.
Immediately call a qualified service technician to inspect the appliance and to replace any part of the control system and any gas control which has been under water.

▲ WARNING ▲

HOT – DO NOT TOUCH - SEVERE BURNS MAY RESULT - CLOTHING IGNITION MAY RESULT

- CAREFULLY SUPERVISE children in same area as the appliance.
- Alert children and adults to hazards of high temperatures.
- Clothing or other flammable materials should not be hung from the appliance or placed on or near the appliance.

▲ WARNING ▲

The appliance should be inspected before use and at least annually by a qualified service technician.

Any guard or protective device removed for servicing must be replaced prior to operation.

Keep the appliance area clear and free from combustible materials, gasoline and other flammable vapors and liquids.

Fire Feature Start Up

1. Prior to turning appliance on visually inspect fire feature to ensure debris such as leaves or other combustible material has not collected inside the feature which could burn and emit embers once the fire feature is turned on. Also ensure any person standing close to the fire feature is aware you will be turning the fire feature on prior to actually turning it on.
2. Turn fire feature on by turning on the electrical device used to power the fire feature.

Sequence of Operation during Normal Operation (see page 14)

Fire Feature Shutdown

1. Turn fire feature off by turning off the electrical device used to power the fire feature.

▲ WARNING ▲

If fire feature fails to turn off completely (small flames still visible)
Turn off gas supply using the manual gas shutoff.

Maintenance

⚠ WARNING ⚠

Maintenance should be done by a qualified service technician.
The appliance should be inspected before use and at least annually by a qualified service technician.

⚠ WARNING ⚠

Ensure gas and power are shut off and appliance is cool before servicing.

⚠ WARNING ⚠

Any guard or protective device removed for servicing must be replaced prior to operation.

Prior to Each Use

1. Inspect for debris in Fire Feature – remove debris prior to use

Semi-Annually

1. Visually inspect Pilot Burner for debris/insect infestation (spider webs)
2. Visually inspect burner holes for debris/insect infestation
3. Clean either of the above as necessary using compressed air.

Annually

1. Visually inspect Pilot Burner for excess corrosion due to heat and moisture.
2. Turn fire feature on to ensure proper operation.

Replacement Parts

Item Letter	Part Name	Part #
A	Fire Ring	FRS
B	Transformer	X24V
C	Ignition Control Box	LDICB
D	Primary Pilot Burner (4 pin connector)	PPBA
E	Secondary Pilot Burner (2 pin connector)	SPBA

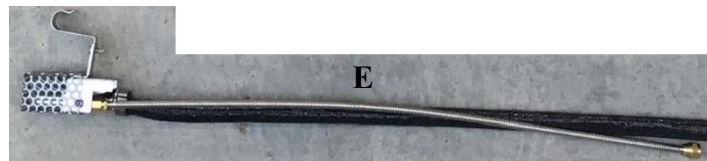
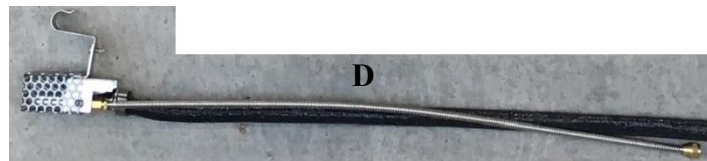
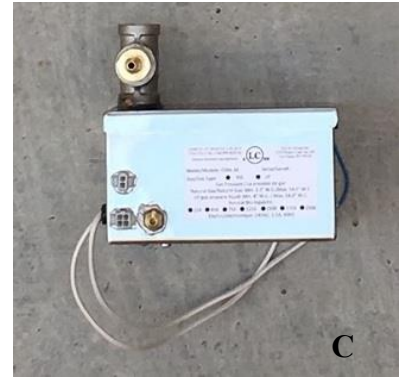
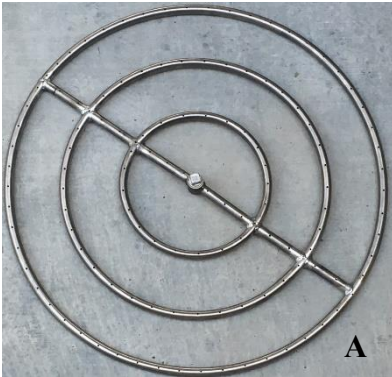

Troubleshooting

I installed the Electronic Ignition System, turned it on and nothing happened

When this occurs it is usually due to an electrical wiring / power issue. Check all your electrical connections thoroughly to ensure all wires at the transformer and inside the fire feature are connected properly. If it appears all wiring is connected properly, disconnect the wires at the fire feature, attach a Multimeter to the wires to confirm a minimum of 24 volts when the fire feature is turned on. If you determine that you do not have a minimum of 24 volts at the fire feature conduct the same test at the transformer to ensure the transformer is in fact producing a minimum of 24 volts. If you do have a minimum of 24 volts at the fire feature contact us for further assistance.

I installed the Electronic Ignition System, turned it on and I can see the glow plug glowing orange and I can hear gas flowing but it will not ignite.

There are two possible causes to this problem; **Air in the Gas Line** or not enough **Electrical Current** to the fire feature.

Air in the Gas Line. If a new gas line was installed and the air was never purged from it prior to installing the Electronic Ignition System then it may take several times of turning the fire feature on and off before the air is purged from the gas line. Here is how our system works; after you turn it on the glow plug will come on first followed by the Pilot Gas Valve opening 4 seconds later. For the next 180 seconds (3 minutes) the glow plug will cycle on and off every 30 seconds while the Pilot Gas Valve will remain on the entire time. Therefore if you are attempting to purge air from the gas line, turn the system on and leave it on for approximately 3 minutes. Then turn it off and then back on (no need to wait to turn it back on). Let the system run for another 3 minutes. Usually when purging air from a new gas line you will need to cycle the power several times as described above before gas begins to flow. If at any point you smell gas but still don't have ignition, attempt to light the Pilot flame with a handheld lighter. If the flame ignites when you light it by hand, go to the section below, "Electrical Current".

Electrical Current. If you have determined that air in the gas line is not the problem then most likely the failure to ignite is due to the fact the glow plug is not getting hot enough to ignite the gas. The reason a glow plug will not get hot enough is due to the fact it is not getting enough 'amps'. Often times when troubleshooting electricians will check the electrical power and when they see they have a minimum of 24 volts they think everything is fine electrically so there must be a problem with the Electronic Ignition System. The problem is not due to the volts but rather the amps. The number of amps reaching the fire feature is heavily dependent on the gauge wire used between the transformer and the fire feature. Our Install Instructions require no less than 12 gauge wire be run for all fire features. Often times we learn that in many cases less than 12 gauge wire has been used and herein lies the cause of the problem.

Here is how you check to determine if enough Electrical Current (amps) are getting to the fire feature:

1. CAUTION: Turn off the gas supply prior to the next step.
2. Using a clamp on ammeter, clamp the ammeter around one of the wires providing power to the Electronic Ignition System.
3. Turn the fire feature on.
4. The amps you should see will range between 1.4 to 1.6 amps initially. Four seconds after being turned on the amps will jump to approximately 2.0 amps.

If you do not see the amps listed above AND the wire gauge used was less than 12 gauge wire – change the wiring. Otherwise contact us for further assistance.

I turned the Fire Feature off but I still see small flames emanating from the fire feature.

Turn the fire feature on, let the main fire ring light and then turn it off again – do this several times. Small pieces of debris from the gas line can get caught in the main or pilot valve thereby preventing it from closing all the way. This will sometimes happen with a new gas line. By cycling power you can often times dislodge the debris. If cycling power does not rectify the problem, turn the gas off using the manual gas shutoff and contact us for further assistance.